

### Pellet cooler introduction and features

Cooling pellets is an essential process in pellet plant. Counterflow pellet cooler can cooling the pellet discharging from pellet mill with temperature 70°C – 90°C to room temperature in short time, and can reduce the safety moisture  $\leq 12.5\%$ , this make pellet convenient to transport, storage and keeping.

Counter flow cooler is a new type of popular cooler on the international market. It is using counter-flow cooling principle to cool the granular pellets of high temperature and high moisture. That is the environmental cold air perpendicular cross to batch layer, in contact with the cold material first, and gradually become the hot air and then in contact with hot materials, the direction of air flow and material flow is in the opposite direction, so that the granules gradually cooling straight-forward. It can be avoided to make the pellet surface occur dehiscence due to cold air and heat pellets in direct contact suddenly like other cooler. As cold air all-wave into the cooler from the bottom, with large air inlet area, cold air is high-usage. Therefore, it with outstanding cooling effect, low energy consumption and easy to operation, So counterflow cooler is upgrade of products which superior than vertical cooler and horizontal cooler.

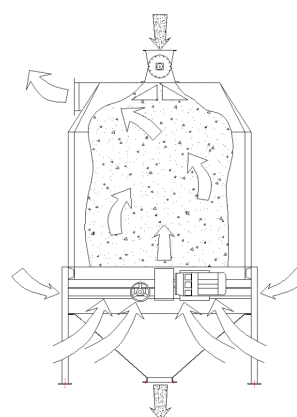
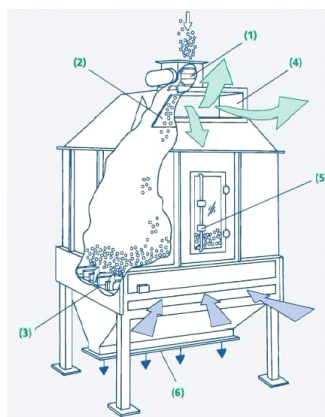
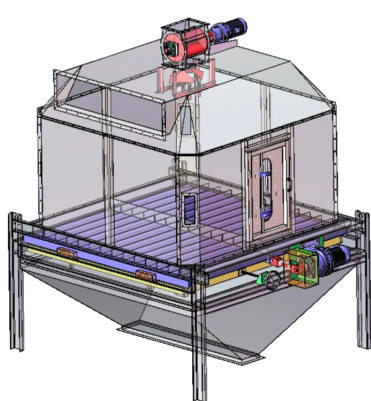

### Pellet cooler technical data

Model	SKLNF1.5	SKLNF2.5	SKLNF4	SKLNF6	SKLNF8
Cooling Capacity (m <sup>3</sup> )	1.5	2.5	4	6	8
Output for wood pellets (t/h)	1-1.5	2-2.5	3-4	4-5	5-6
Cooling Time (min)	$\geq 6 \sim 10$ min				
After Cooling Temperature	only +3~5°C higher than room temperature				
Equipped Power(KW)	0.75	0.75	1.5	1.5	1.5
Air Shutter Power(KW)	0.37	0.55	0.55	0.55	0.55
Air volume(m <sup>3</sup> /h)	5040~7120	10080~ 12240	16800~ 20400	25200~ 30600	33600~ 40800
Wind pressure(mm)	200	200	200	200	200
Model of air blower	4-72-11 NO4A	4-72-11 NO5A	4-72-11 NO6C	4-72-11 NO8C	4-72-11 NO10C
Power of air blower (KW)	5.5	7.5	15	22	30